

---

## C8051T606 DEVELOPMENT KIT USER'S GUIDE

---

### 1. Kit Contents

The C8051T606 Development Kit contains the following items:

- C8051T606 Main Board
- C8051T606 MSOP Socket Daughter Board for programming MSOP devices
- C8051T600 Emulation Daughter Board with C8051F300 installed
- (5) C8051T606-GT Samples
- C8051T606 Development Kit Quick-Start Guide
- Silicon Laboratories IDE and Product Information CD-ROM. CD content includes the following:
  - Silicon Laboratories Integrated Development Environment (IDE)
  - Evaluation assembler, compiler and linker tools
  - Source code examples and register definition files
  - Documentation
- AC to DC Universal Power Adapter
- USB Cable
- RS-232 Cable

Also available for purchase separately are socket daughter boards for the QFN-11 and QFN-10 packages.

### 2. About the Daughter Boards

The C8051T606 Development Kit includes two daughter boards: a C8051T600 Emulation Daughter Board and a C8051T606 MSOP Socket Daughter Board. The emulation daughter board has a C8051F300 device installed, which is a Flash-based device which can be used as a firmware development platform for the C8051T606. The MSOP socket daughter board as well as the 10 and 11-pin QFN socket daughter boards (available separately) are intended to allow programming of multiple C8051T606 devices and system-level debugging of these devices. Once any byte location in a C8051T606 device has been programmed it cannot be erased, so it is advisable to use the C8051F300 for the majority of code development. Refer to Application Note "AN280: Differences Between the C8051F300 and the C8051T60x Device Family" for more details on how the C8051F300 can be used to develop code for the C8051T606 and other members of the C8051T60x device family.

### 3. Hardware Setup

Refer to Figure 1 for a diagram of the hardware configuration.

1. Attach the desired daughter board to the main board at connectors P1 and P2.
2. If using one of the socketed daughter boards, place the device to be programmed into the socket.
3. Connect the AC to DC power adapter to connector P3 on the main board.
4. Connect the main board to a PC running the Silicon Laboratories IDE using the USB cable.

#### Notes:

- Use the **Reset** icon in the IDE to reset the target when connected during a debug session.
- Remove power from the main board and remove the USB cable before removing a daughter board from the main board. Connecting or disconnecting a daughter board when the power adapter or USB cable are connected can damage the main board, the daughter board, or the socketed device.
- Likewise, remove power from the main board and remove the USB cable before removing a C8051T606 device from the socket. Inserting or removing a device from the socket when the power adapter or USB cable are connected can damage the main board, the daughter board, or the socketed device.



## 5.2. Third-Party Toolsets

The Silicon Laboratories IDE has native support for many 8051 compilers. Natively-supported tools are as follows:

- Keil
- IAR
- Raisonance
- Tasking
- Hi-Tech
- SDCC

Specific instructions for integrating each of the supported tools can be found in the application notes section of the CD, or on the Silicon Labs web site (<http://www.silabs.com>).

## 5.3. Getting Started With the Silicon Labs IDE

The following sections discuss how to create a new project with the IDE, build the source code, and download it to the target device.

### 5.3.1. Creating a New Project

1. Select **Project**→**New Project** to open a new project and reset all configuration settings to default.
2. Select **File**→**New File** to open an editor window. Create your source file(s) and save the file(s) with a recognized extension, such as .c, .h, or .asm, to enable color syntax highlighting.
3. Right-click on “New Project” in the **Project Window**. Select **Add files to project**. Select files in the file browser and click Open. Continue adding files until all project files have been added.
4. For each of the files in the **Project Window** that you want assembled, compiled and linked into the target build, right-click on the file name and select **Add file to build**. Each file will be assembled or compiled as appropriate (based on file extension) and linked into the build of the absolute object file.

**Note:** If a project contains a large number of files, the “Group” feature of the IDE can be used to organize. Right-click on “New Project” in the **Project Window**. Select **Add Groups to project**. Add pre-defined groups or add customized groups. Right-click on the group name and choose **Add file to group**. Select files to be added. Continue adding files until all project files have been added.

### 5.3.2. Building and Downloading the Program for Debugging

1. Once all source files have been added to the target build, build the project by clicking on the **Build/Make Project** button in the toolbar or selecting **Project**→**Build/Make Project** from the menu.

**Note:** After the project has been built the first time, the **Build/Make Project** command will only build the files that have been changed since the previous build. To rebuild all files and project dependencies, click on the **Rebuild All** button in the toolbar or select **Project**→**Rebuild All** from the menu.

2. Before connecting to the target device, several connection options may need to be set. Open the **Connection Options** window by selecting **Options**→**Connection Options...** in the IDE menu. First, select the “USB Debug Adapter” option. The USB Debug circuitry is integrated onto the C8051T606 main board. Next, the correct “Debug Interface” must be selected. C8051T606 devices and the C8051F300 use Silicon Labs “C2” 2-wire debug interface. Once all the selections are made, click the **OK** button to close the window.
3. Click the **Connect** button in the toolbar or select **Debug**→**Connect** from the menu to connect to the device.
4. Download the project to the target by clicking the **Download Code** button in the toolbar.

**Note:** To enable automatic downloading if the program build is successful select **Enable automatic connect/download after build** in the **Project**→**Target Build Configuration** dialog. If errors occur during the build process, the IDE will not attempt the download.

# C8051T606-DK

---

5. Save the project when finished with the debug session to preserve the current target build configuration, editor settings and the location of all open debug views. To save the project, select **Project**→**Save Project As...** from the menu. Create a new name for the project and click on **Save**.

## 6. Example Source Code

Example source code and register definition files are provided in the “*SiLabs\MCU\Examples\C8051T60x*” directory during IDE installation. These files may be used as a template for code development. The comments in each example file indicate which development tool chains were used when testing the.

### 6.1. Register Definition Files

Register definition files *C8051T600.inc*, *C8051T600\_defs.h* and *compiler\_defs.h* define all SFR registers and bit-addressable control/status bits. They are installed into the “*SiLabs\MCU\Examples\C8051T60x*” directory during IDE installation. The register and bit names are identical to those used in the C8051T60x datasheet.

## 7. Development Boards

The C8051T606 Development Kit includes a main board which interfaces to various daughter boards. The “C8051T600 Emulation Daughter Board” contains a C8051F300 device to be used for preliminary software development. The socketed C8051T606 daughter boards allow programming and evaluation of the actual C8051T606 devices. Numerous input/output (I/O) connections are provided on the main board to facilitate prototyping. Refer to Figure 2 for the locations of the various connectors on the main board. Figure 3, Figure 4 and Figure 5 show the available daughter boards that can be used with the C8051T606 main board.

- P1, P2 Daughter board connection (Daughter boards are plugged into the P1 and P2 connectors for evaluation and programming)
- P3 Power connector (accepts input from 7.5 to 15 VDC unregulated power adapter)
- J1 USB Debug connector
- J2 RS-232 connector
- J3 LED/Switch/RS-232 connection block
- J8 Direct device pin connection block
- J10 VPP supply connection (used when programming EPROM devices)

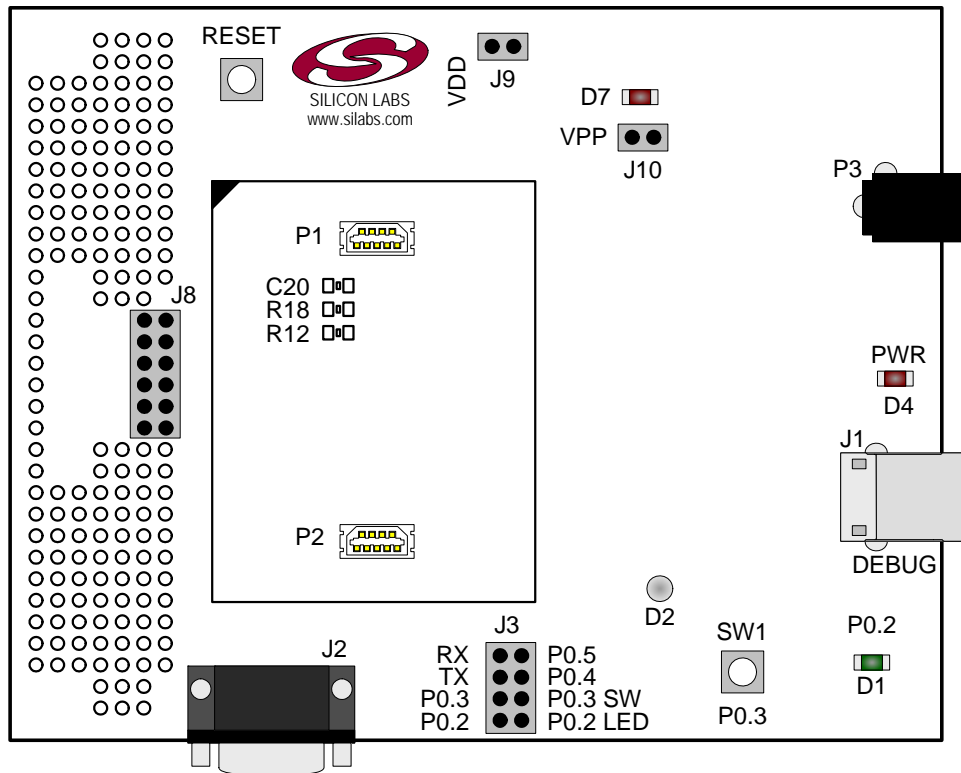

Figure 2. C8051T606 Main Board (Included in Kit)

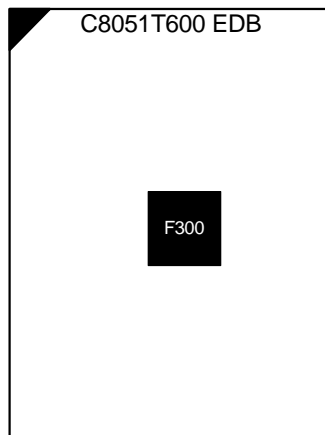
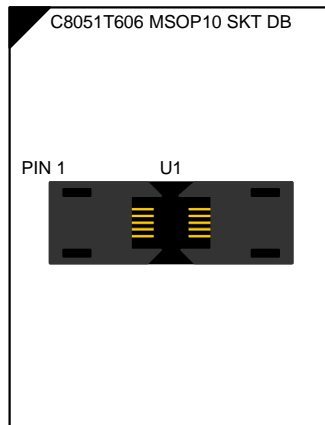
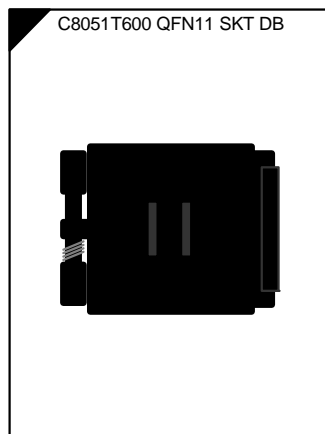

Figure 3. C8051T606 Evaluation Daughter Board (Included in Kit)



**Figure 4. C8051T600 MSOP10 Socket Daughter Board (Included in Kit)**



**Figure 5. C8051T600 3x3mm QFN11 Socket Daughter Board (Available Separately)**

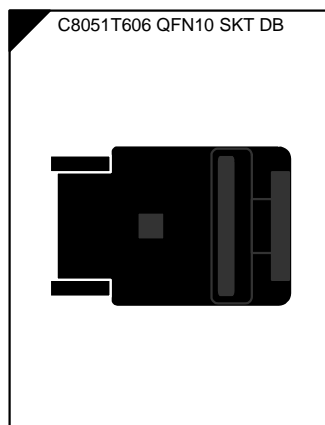

**Figure 6. C8051T606 2x2mm QFN10 Socket Daughter Board (Available Separately)**

## 7.1. System Clock Sources

The C8051T606 devices feature a calibrated internal oscillator which is enabled as the system clock source on reset. After reset, the internal oscillator operates at a frequency of 24.5 MHz ( $\pm 2\%$ ) by default, but may be configured by software to operate at other frequencies. Therefore, in many applications an external oscillator is not required. However, if you wish to operate the C8051T606 device at a frequency not available with the internal oscillator, an external oscillator source may be used. Refer to the C8051T600/1/2/3/4/5/6 datasheet for more information on configuring the system clock source.

The main board is designed to facilitate the use of external clock sources. To use an external CMOS clock source, the clock can simply be applied to P0.3. To implement the RC mode option, placeholders for an 0805-packaged capacitor (C20) and resistor (R18) are supplied on the board. The C (capacitor) clock option can be implemented by using only the capacitor placeholder (C20). To reduce the amount of stray capacitance on the pin, which could affect the frequency in either RC or C mode, resistor R12 can also be removed from the board when using C or RC mode. Refer to the C8051T600/1/2/3/4/5/6 datasheet for more information on the use of external oscillators.

## 7.2. Switches and LEDs

Two switches are provided on the main board. Switch RESET is connected to the RESET pin of the C8051T606. Pressing RESET puts the device into its hardware-reset state. Switch P0.3 can be connected to the C8051T606's general purpose I/O (GPIO) pin P0.3 through header J3. Pressing Switch P0.3 generates a logic low signal on the port pin. Remove the shorting block from the J3 header to disconnect Switch P0.3 from the port pin.

Four LEDs are also provided on the target board. The red LED labeled PWR (D4) is used to indicate a power connection to the target board. The red/green LED labeled D2 is the run/stop light for the debug circuitry. The red LED labeled D7 indicates when the VPP programming voltage is being applied to the device (see Section 7.6 for additional details). Finally, the green LED labeled P0.2 (D1) can be connected to the C8051T606's GPIO pin P0.2 through header J3. Remove the shorting block from the header to disconnect the LED from the port pin. Note that when this LED is connected, it will also light when programming EPROM devices.

See Table 1 for the port pins and headers corresponding to the switches, LEDs, and potentiometer.

**Table 1. Target Board I/O Descriptions**

Description	I/O	Header
SW1	P0.3	J3[5–6]
SW2	RESET	none
Red LED	PWR	none
Green LED	P0.2	J3[7–8]
Red/Green LED	none	none
Red LED	VPP	J10

## 7.3. USB Debug Interface (DEBUG/J1)

A Universal Serial Bus (USB) connector (J1) is included to provide the on-board debug and programming interface. The debug/programming interface is powered through the USB connector, but requires power to the device via the power connector P3 in order to initiate debug and programming operations.

# C8051T606-DK

---

## 7.4. PORT I/O Connector (J8)

Each of the C8051T606's I/O pins, as well as VPP, +3VD, GND, and /RST are routed to header J8. This header can be used to easily connect to any signal on the device. Table 2 defines the pins for header J8.

**Table 2. J8 Pin Descriptions**

Pin #	Description
1	+3VD (+3.3 VDC)
2	VPP
3	no connection
4	P0.1
5	P0.2
6	P0.3
7	P0.4
8	P0.5
9	no connection
10	P0.7
11	GND
12	/RST

## 7.5. Serial Interface (J2)

A RS232 transceiver circuit and DB-9 (J2) connector are provided on the main board to facilitate serial connections to UART0 on the C8051T606. The TX and RX signals of UART0 may be connected to the RS-232 transceiver by installing shorting blocks on header J3. The RTS and CTS lines do not have a direct connection available to the C8051T606, due to limited pin resources on the device. However, these two signals have also been routed through the transceiver, and are available for wiring on-board at test points near the DB-9 connector. The transceiver shifts the UART signals to RS-232 levels, and connects to the appropriate pins on the DB-9 connector.

- J3[1–2] —Install shorting block to connect UART0 RX (P0.5) to transceiver.
- J3[3–4] —Install shorting block to connect UART0 TX (P0.4) to transceiver.



## 7.6. VPP Connection (J10)

The C8051T606 devices require a special 6.0 V programming voltage applied to the VPP pin during device programming. The VPP pin on these devices is shared with P0.2. During programming, the VPP voltage is automatically enabled when needed. Header J10 is provided to allow the user to disconnect the programming circuitry from the VPP/P0.2 pin to avoid interfering with the normal application operation of P0.2. When programming the device, J10 should be shorted with a shorting block. When running normal application code, J10 can be removed. Note that the C8051T600 emulation daughter board does not connect the main board's VPP and P0.2 signals, so removing the shorting block is not necessary when using the emulation daughter board.

## 7.7. Using Alternate Supplies with the C8051T60x Development Kit

For most evaluation purposes, the on-board 3.3 V supply regulator is sufficient to be used as a VDD power supply. However, in applications where a different supply voltage is desired (for example, 1.8 V), an external supply voltage can be applied to the board at the analog connector (J6). Depending on the supply and the desired functionality of the board, it may be necessary to cut the VDD supply voltage trace on the back of the board behind header J9 (not populated). The following should be considered when supplying a different voltage to the device:

1. **When programming a C8051T606 device:** The on-board 3.3 V regulator should be used for VDD.
2. **If a VDD supply voltage between 2.7 and 3.6 V is desired:** The ac to dc power adapter should be disconnected from P3, and the desired supply voltage can be applied directly to the GND and VDD terminals of terminal block J6. No board modification is necessary.
3. **If a VDD supply voltage between 1.8 and 2.7 V is desired and RS-232 functionality is not required:** The ac to dc power adapter should be disconnected from P3, and the desired supply voltage can be applied directly to the GND and VDD terminals of terminal block J6. No board modification is necessary.
4. **If a VDD supply voltage between 1.8 and 2.7 V is desired and RS-232 functionality is required:** The RS-232 transceiver is not specified to operate below 2.7 V. In this case, the trace under header J9 should be cut. Then, the desired VDD supply voltage can be applied directly to the GND and VDD terminals of terminal block J6, and the ac to dc power adapter can be connected to P3, to provide 3.3 V to the RS-232 transceiver. In this case, it may also be necessary to configure the TX pin on the device for open-drain mode, and add a pull-up resistor to the supply of the transceiver.

## 8. Schematics

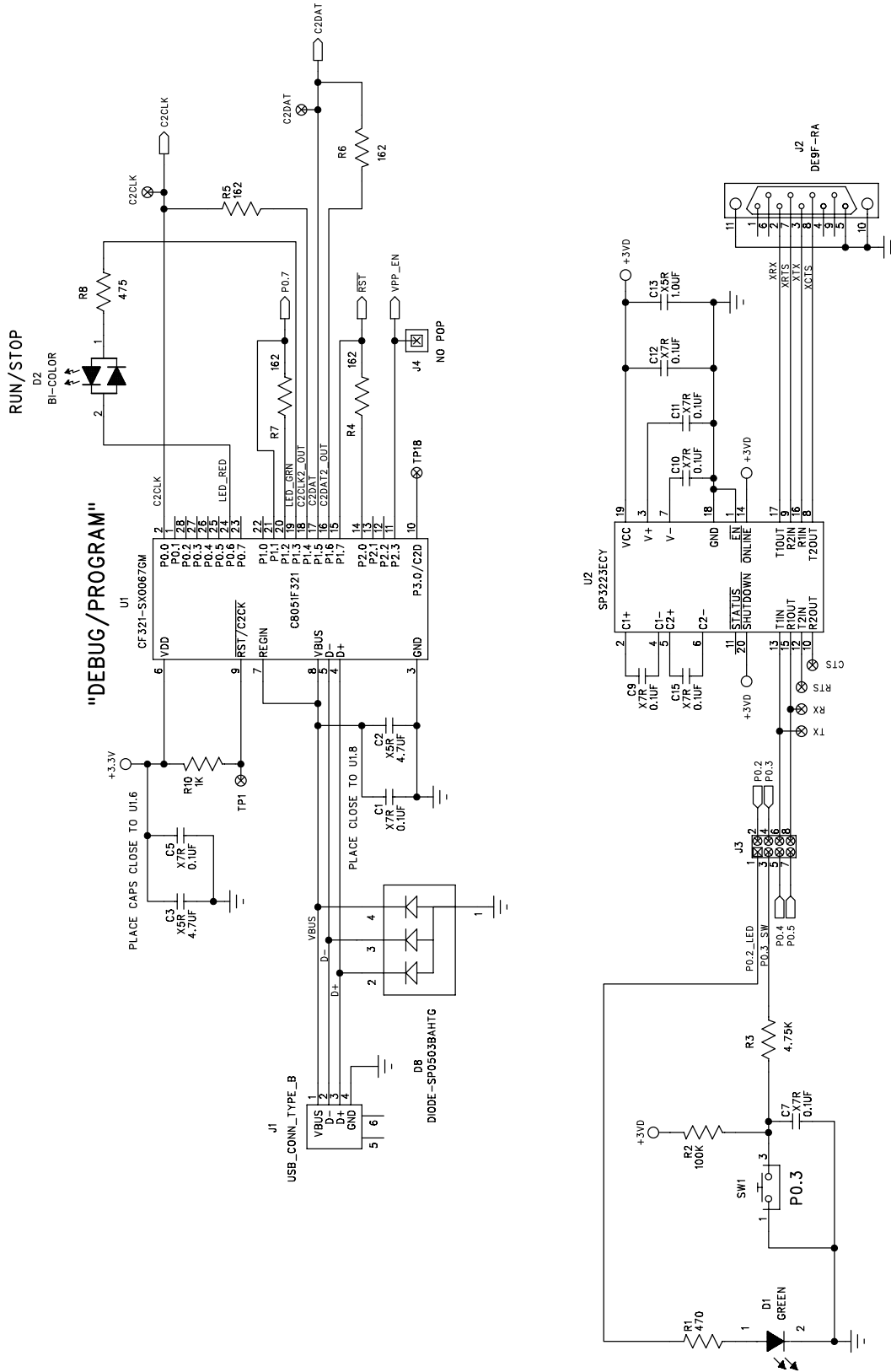

Figure 7. C8051T600 Main Board Schematic (page 1/2)

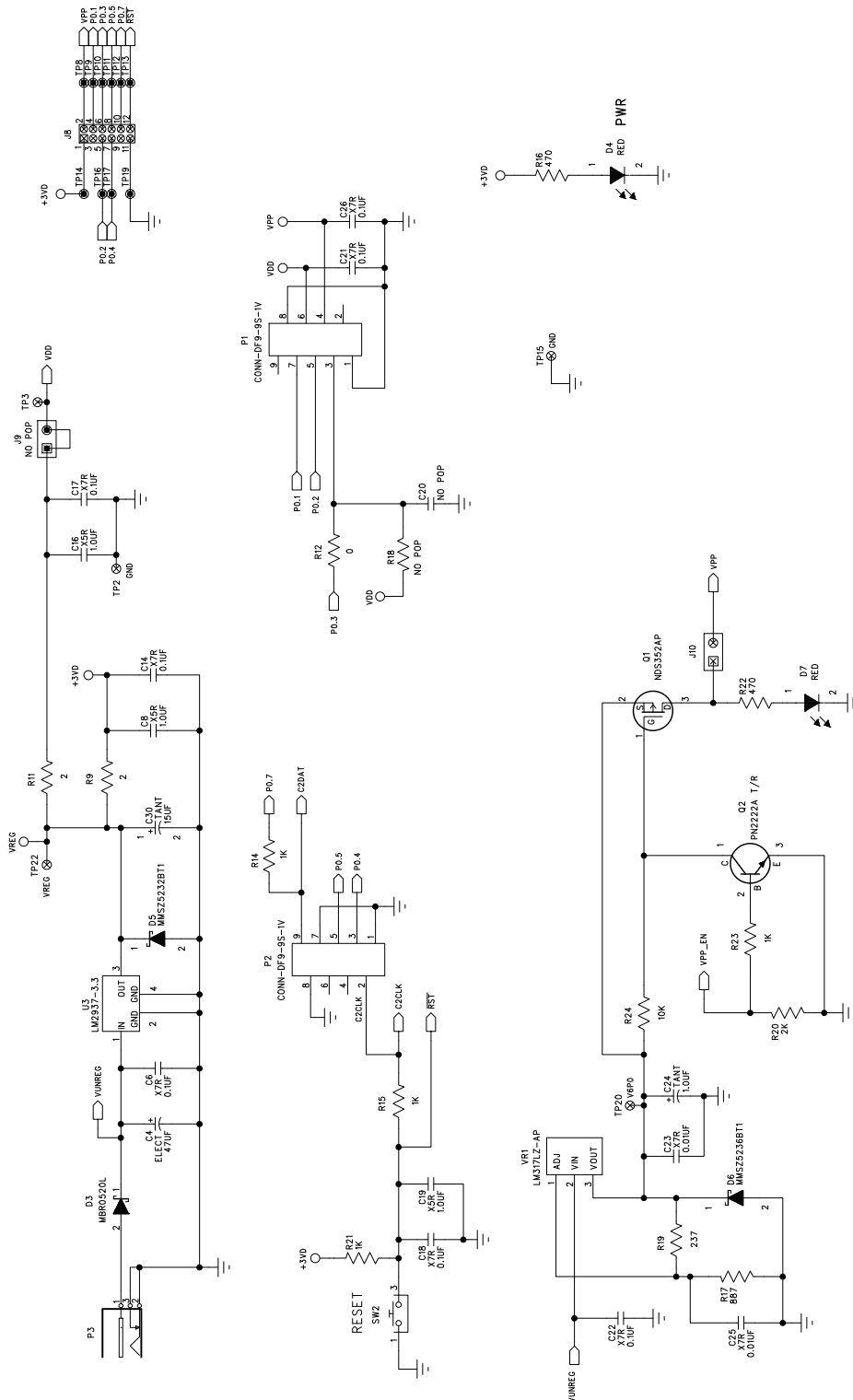

Figure 8. C8051T600 Main Board Schematic (page 2/2)

# C8051T606-DK

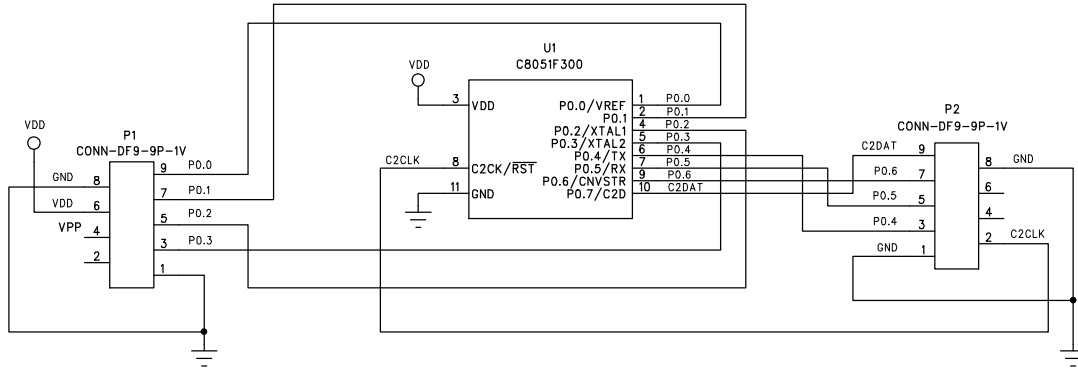

Figure 9. C8051T600 Emulation Daughter Board Schematic

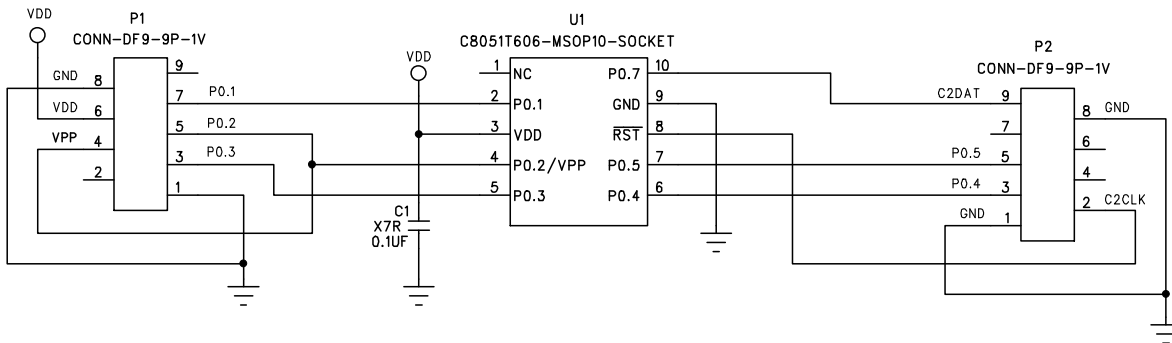

Figure 10. C8051T606 MSOP10 Socket Daughter Board Schematic

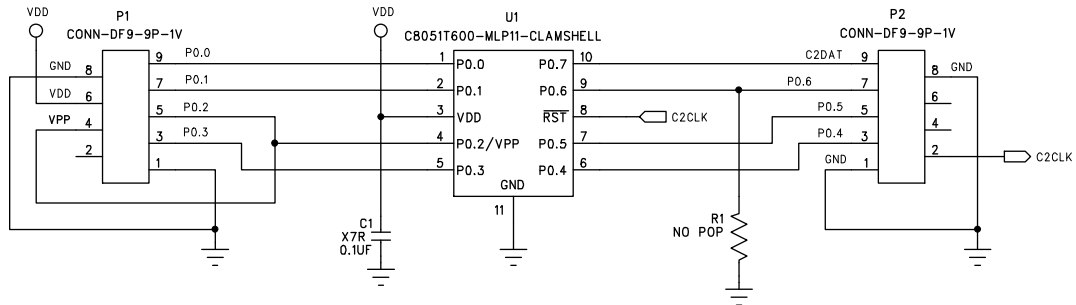

Figure 11. C8051T600 QFN11 Socket Daughter Board Schematic

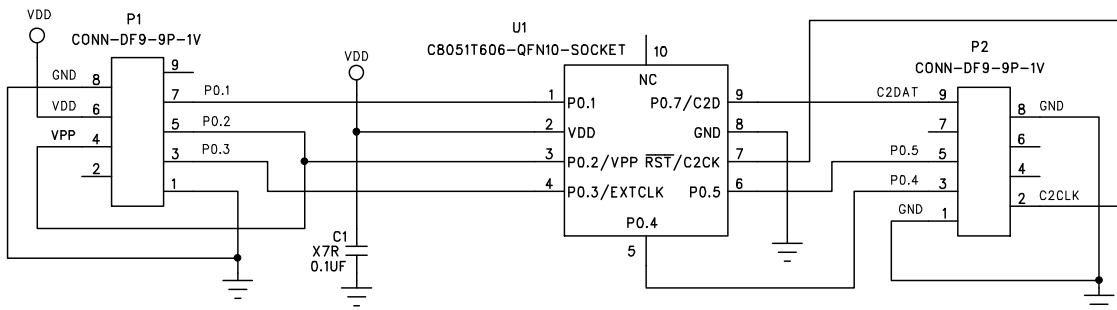

Figure 12. C8051T606 QFN10 Socket Daughter Board Schematic

**NOTES:**

## CONTACT INFORMATION

Silicon Laboratories Inc.  
4635 Boston Lane  
Austin, TX 78735  
Tel: 1+(512) 416-8500  
Fax: 1+(512) 416-9669  
Toll Free: 1+(877) 444-3032

Please visit the [Silicon Labs Technical Support](#) web page and register to submit a technical support request.

The information in this document is believed to be accurate in all respects at the time of publication but is subject to change without notice. Silicon Laboratories assumes no responsibility for errors and omissions, and disclaims responsibility for any consequences resulting from the use of information included herein. Additionally, Silicon Laboratories assumes no responsibility for the functioning of undescribed features or parameters. Silicon Laboratories reserves the right to make changes without further notice. Silicon Laboratories makes no warranty, representation or guarantee regarding the suitability of its products for any particular purpose, nor does Silicon Laboratories assume any liability arising out of the application or use of any product or circuit, and specifically disclaims any and all liability, including without limitation consequential or incidental damages. Silicon Laboratories products are not designed, intended, or authorized for use in applications intended to support or sustain life, or for any other application in which the failure of the Silicon Laboratories product could create a situation where personal injury or death may occur. Should Buyer purchase or use Silicon Laboratories products for any such unintended or unauthorized application, Buyer shall indemnify and hold Silicon Laboratories harmless against all claims and damages.

Silicon Laboratories and Silicon Labs are trademarks of Silicon Laboratories Inc.

Other products or brandnames mentioned herein are trademarks or registered trademarks of their respective holders.

# Mouser Electronics

Authorized Distributor

Click to View Pricing, Inventory, Delivery & Lifecycle Information:

[Silicon Laboratories:](#)

[C8051T606DK](#)